

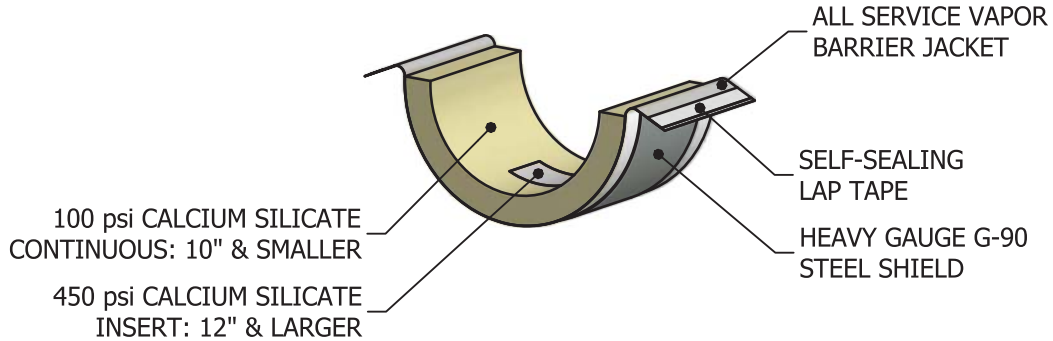

Quik-Shield



Description / Features

Quik-Shields are economically priced 180° thermal hanger shields providing a continuous section of insulation and zero permeability vapor barrier through a variety of pipe hangers. The vapor barrier jacket extends beyond the galvanized steel shield and beyond the insulation insert for a neat, vapor-tight fit with both the adjoining and the field-applied top insulation. To assure proper support in all situations, high density compressive strength 450 psi structural inserts are installed in units for 10" pipe with 1" insulation thickness and in all units for 12" pipe and larger.

Applications

- For use on flat surfaces, clevis or other band-type hangers.
- Pipe sizes 16" and larger in clevis hangers only.
- Chilled to steam piping and dual temperature lines.
- Hanger spans per MSS SP-58 Table A3.
- Available for pipe 1/2" through 24", insulation thickness 1/2" through 4".

Materials / Construction

- 100 psi compressive strength calcium silicate meeting ASTM C-533 Type I, C-585, C-795, E-84 Flame Spread/Smoke Developed: 0/0, Thermal Conductivity = 0.39 Btu•in/(hr•ft²•°F) @ 200°F.
- Adhesive complying with NFPA 90-A, ASTM E-84 Flame Spread/Smoke Developed: 5/0.
- G-90 Galvanized steel shield, small check per ASTM A-653 (replaces A-527).
- Zero permeability vapor barrier of all service jacket meeting ASTM D-774, D-828 and E-84 Flame Spread/Smoke Developed: 10/20.
- Structural insert (12" pipe and larger) minimum 450 psi compressive strength calcium silicate meeting ASTM C-656 Type II Grade 5, C-795 and E-84 Flame Spread/Smoke Developed: 0/0.
- All units and components are asbestos free and 100% made and assembled in the U.S.A.

DIMENSIONS

PIPE SIZE	1/2" TO 1 1/2"	2" TO 5"	6" TO 8"	10" TO 12"	14" TO 24"
INSULATION LENGTH - in.	6	6	9	9	12
SHIELD LENGTH - in.	4	4	6	6	10
SHIELD GAUGE	22	20	16	14	12
COMPRESSIVE STRENGTH - psi	100	100	100	100 / 450	100 / 450

ALLOWABLE LOADS / RECOMMENDED SPANS

PIPE SIZE	1/2"	1"	1 1/2"	2"	3"	4"	6"	8"	10"	12"	14"	16"	18"	20"	24"
CLEVIS	80 lbf 7 ft.	130 lbf 7 ft.	185 lbf 9 ft.	230 lbf 10 ft.	325 lbf 10 ft.	380 lbf 10 ft.	605 lbf 10 ft.	800 lbf 10 ft.	1160 lbf 10 ft.	1400 lbf 10 ft.	1800 lbf 10 ft.	2600 lbf 10 ft.	3300 lbf 10 ft.	4000 lbf 10 ft.	6175 lbf 10 ft.
TRAPEZE	40 lbf 7 ft.	60 lbf 7 ft.	85 lbf 9 ft.	130 lbf 10 ft.	165 lbf 10 ft.	170 lbf 10 ft.	330 lbf 10 ft.	510 lbf 10 ft.	830 lbf 10 ft.	1200 lbf 10 ft.	1250 lbf 10 ft.	See MaxSpan	See MaxSpan	See MaxSpan	See MaxSpan