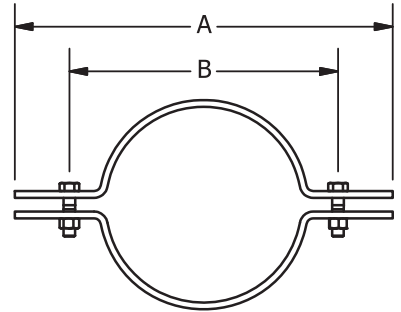



FIG. 420

Riser Clamp, PVC



SERVICE: For supporting vertical pipe runs. PVC risers prevent pipe from coming in contact with the clamp and causing electrolysis between pipe and clamp. They are also designed to reduce noise and vibration.

MATERIAL: Carbon Steel

FINISH: PVC coated riser clamps are completely Plastic Coated with Electro-Galvanized hardware.

STANDARDS: MSS SP-58 Type 8, FS WW-H-171E Type 8

APPROVALS: UL (2" - 8")

ORDERING: Specify figure number and pipe size.

PIPE SIZE	A	B	STOCK SIZE	BOLT SIZE	WEIGHT EACH, LBS.	MAX. REC. LOAD, LBS.
1/2	8 ⁵ / ₈	2 ¹ / ₈	8ga x 1	3/8 x 1 ¹ / ₂	0.88	220
3/4	8 ¹³ / ₁₆	2 ⁵ / ₁₆	8ga x 1	3/8 x 1 ¹ / ₂	0.92	220
1	9 ¹ / ₁₆	2 ⁵ / ₈	8ga x 1	3/8 x 1 ¹ / ₂	0.94	220
1 ¹ / ₄	9 ⁷ / ₁₆	2 ¹⁵ / ₁₆	8ga x 1	3/8 x 1 ¹ / ₂	1.00	250
1 ¹ / ₂	10	3 ⁷ / ₁₆	8ga x 1	3/8 x 1 ¹ / ₂	1.04	250
2	10 ⁹ / ₁₆	4	8ga x 1	3/8 x 1 ¹ / ₂	1.14	300
2 ¹ / ₂	11 ¹ / ₈	4 ⁹ / ₁₆	3ga x 1	3/8 x 1 ¹ / ₂	1.60	400
3	11 ¹³ / ₁₆	5 ¹ / ₄	3ga x 1	3/8 x 1 ¹ / ₂	1.70	500
4	13 ⁵ / ₈	6 ⁵ / ₈	3ga x 1	1/2 x 1 ¹ / ₂	2.20	750
5	14 ¹ / ₈	7 ⁵ / ₈	3ga x 1 ¹ / ₂	1/2 x 1 ³ / ₄	3.40	1500
6	15 ³ / ₈	8 ⁷ / ₈	3ga x 1 ¹ / ₂	1/2 x 1 ³ / ₄	3.72	1600
8	18 ⁵ / ₈	12	3/8 x 1 ¹ / ₂	5/8 x 2 ¹ / ₂	7.22	2500
10	21	14 ¹ / ₂	3/8 x 2	5/8 x 2 ¹ / ₂	10.94	2500