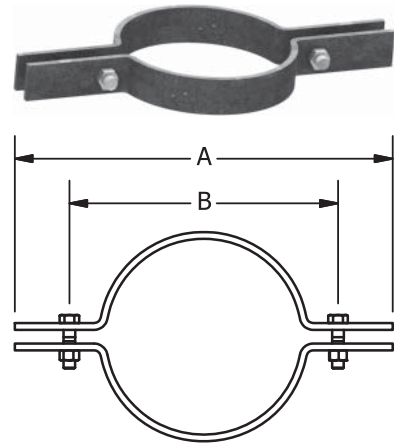



FIG. 420

Riser Clamp

- SERVICE:** For support of vertical pipe runs.
- MATERIAL:** Carbon Steel or 304/316 Stainless Steel
- FINISH:** Black, Electro-Galvanized, Hot-Dip Galvanized
- STANDARDS:** MSS SP-58 Type 8, FS WW-H-171E Type 8
- APPROVALS:** UL (2" - 8")
- ORDERING:** Specify figure number, pipe size, material and finish.



PIPE SIZE	A	B	STOCK SIZE	BOLT SIZE	WEIGHT EACH, LBS.	MAX. REC. LOAD, LBS.
1/2	8 ⁵ / ₈	2 ¹ / ₈	8ga x 1	3/8 x 1 1/2	0.88	220
3/4	8 ⁹ / ₁₆	2 ⁵ / ₁₆	8ga x 1	3/8 x 1 1/2	0.92	220
1	9 ¹ / ₁₆	2 ⁵ / ₈	8ga x 1	3/8 x 1 1/2	0.94	220
1 1/4	9 ⁷ / ₁₆	2 ¹⁵ / ₁₆	8ga x 1	3/8 x 1 1/2	1.00	250
1 1/2	10	3 ⁷ / ₁₆	8ga x 1	3/8 x 1 1/2	1.04	250
2	10 ⁹ / ₁₆	4	8ga x 1	3/8 x 1 1/2	1.14	300
2 1/2	11 ¹ / ₈	4 ⁹ / ₁₆	3ga x 1	3/8 x 1 1/2	1.60	400
3	11 ¹³ / ₁₆	5 ¹ / ₄	3ga x 1	3/8 x 1 1/2	1.70	500
4	13 ⁵ / ₈	6 ⁵ / ₈	3ga x 1	1/2 x 1 1/2	2.20	750
5	14 ¹ / ₈	7 ⁵ / ₈	3ga x 1 1/2	1/2 x 1 3/4	3.40	1500
6	15 ³ / ₈	8 ⁷ / ₈	3ga x 1 1/2	1/2 x 1 3/4	3.72	1600
8	18 ¹ / ₂	12 ¹ / ₂	3/8 x 1 1/2	5/8 x 2 1/2	7.20	2500
10	20 ³ / ₄	14 ³ / ₄	3/8 x 2	5/8 x 2 3/4	11.00	2500
12	22 ³ / ₄	16 ³ / ₄	1/2 x 2	5/8 x 3 1/4	16.10	2700
14	24	18	1/2 x 2	5/8 x 3 1/4	17.00	2700
16	26	21	5/8 x 2 1/2	3/4 x 4	29.16	2900
18	28	23	5/8 x 2 1/2	3/4 x 4	32.40	2900
20	30	25	5/8 x 2 1/2	3/4 x 4 1/2	35.00	2900
24	36	29 ¹ / ₄	5/8 x 2 1/2	7/8 x 4 1/2	43.00	2900
30	42	35 ³ / ₄	3/4 x 4	1 x 5	95.00	3200