



**FIG. 300**

**Pipe Covering Protection Shield**

**SERVICE:** For use on the outside of foam or fiber glass insulation.  
**MATERIAL:** Carbon Steel or 304/316 Stainless Steel  
**FINISH:** Pre-Galvanized  
**ORDERING:** Specify figure number, shield size and material.

SHIELD SIZE NO.	LENGTH	STOCK SIZE C	DIA. D	HANGER SIZE	WEIGHT PER 100, LBS.
0	12	24ga	1 <sup>7</sup> / <sub>8</sub>	1 <sup>1</sup> / <sub>2</sub>	25
1	12	24ga	2 <sup>3</sup> / <sub>8</sub>	2	31
2	12	24ga	2 <sup>7</sup> / <sub>8</sub>	2 <sup>1</sup> / <sub>2</sub>	37
3	12	18ga	3 <sup>1</sup> / <sub>2</sub>	3	93
4	12	18ga	4	3 <sup>1</sup> / <sub>2</sub>	103
5	12	18ga	4 <sup>1</sup> / <sub>2</sub>	4	118
6	12	18ga	5	5	133
7	12	18ga	5 <sup>9</sup> / <sub>16</sub>	5	147
8	12	18ga	6 <sup>5</sup> / <sub>8</sub>	6	165
9	12	18ga	7 <sup>3</sup> / <sub>8</sub>	8	190
10	12	18ga	8 <sup>5</sup> / <sub>8</sub>	8	210
13	12	18ga	9 <sup>3</sup> / <sub>8</sub>	10	235
14	12	18ga	10 <sup>3</sup> / <sub>4</sub>	10	265
15	12	18ga	11 <sup>3</sup> / <sub>4</sub>	12	295
16	12	18ga	12 <sup>3</sup> / <sub>4</sub>	12	315
17	12	16ga	14	14	445
18	12	16ga	15	16	446
19	12	16ga	16	16	490
20	12	16ga	17	18	515
21	12	16ga	18	18	550
22	12	16ga	19	20	570
23	12	16ga	20	20	635
24	12	16ga	21	24	645
25	12	16ga	22	24	660
26	12	16ga	23	24	700
27	12	16ga	24	24	785
28	12	16ga	26	30	790
29	12	16ga	27	30	805
30	12	16ga	28	30	860

SHIELD SIZE SELECTION TABLE FOR TUBING					
TUBING SIZE	A - Insulation Thickness				
	1/2	3/4	1	1 1/2	2
1/2	0	1	2	4	5
3/4	0	1	2	4	6
1	1	2	3	4	6
1 1/4	1	2	3	5	7
1 1/2	2	3	3	5	7
2	3	4	4	6	8
2 1/2	4	5	5	7	8
3	5	6	6	8	9
3 1/2	6	7	7	8	9
4	7	7	8	9	10
5	8	8	9	10	13
6	9	9	10	13	14

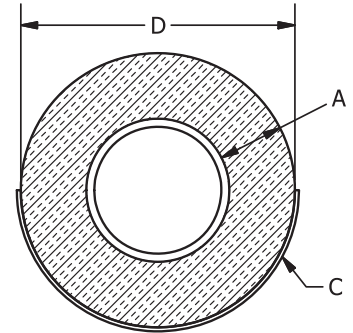
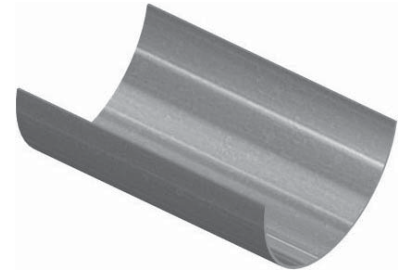

SHIELD SIZE SELECTION TABLE FOR PIPE					
PIPE SIZE	A - Insulation Thickness				
	1/2	3/4	1	1 1/2	2
1/2	0	1	-	-	-
3/4	1	1	2	4	6
1	1	2	3	5	7
1 1/4	2	3	3	6	7
1 1/2	2	3	4	6	7
2	3	4	5	7	8
2 1/2	4	5	6	7	8
3	5	6	7	8	9
3 1/2	-	-	8	9	10
4	-	-	8	9	10
5	-	-	9	10	13
6	-	-	10	13	14
8	-	-	14	15	16
10	-	-	16	17	18
12	-	-	18	19	20
14	-	-	19	20	21
16	-	-	21	22	23
18	-	-	23	24	25
20	-	-	25	26	27
24	-	-	28	29	30