



FIG. 165
FIG. 166

U-Bolt
U-Bolt for DI Pipe

SERVICE: For support, anchor or guide of heavy loads.
MATERIAL: Carbon Steel or 304/316 Stainless Steel
FINISH: Black, Electro-Galvanized or Hot-Dip Galvanized
STANDARDS: MSS SP-58 Type 24, FS WW-H-171E Type 24
ORDERING: Specify figure number, pipe size, material and finish. (Each FIG. #165 U-Bolt is furnished with four FIG. #785 Hex Nuts. Each FIG. #166 U-Bolt is furnished with four FIG. #790 Hex Nuts.)



FIG. #165						
PIPE SIZE	A	B	C	T	WEIGHT EACH, LBS.	MAX. REC. LOAD, LBS.
1/2	1/4	2 3/4	1 3/16	2 3/8	0.11	485
3/4	1/4	2 3/4	1 3/8	2 3/8	0.12	485
1	1/4	2 3/4	1 5/8	2 3/8	0.12	485
1 1/4	3/8	2 7/8	2 1/16	2 3/8	0.28	1220
1 1/2	3/8	3	2 3/8	2 1/2	0.30	1220
2	3/8	3 1/4	2 13/16	2 1/2	0.33	1220
2 1/2	1/2	3 3/4	3 3/16	3	0.73	2260
3	1/2	4	4 1/16	3	0.78	2260
3 1/2	1/2	4 1/4	4 9/16	3	0.84	2260
4	1/2	4 1/2	5 1/16	3	0.90	2260
5	1/2	5	6 1/8	3	1.01	2260
6	5/8	6 1/8	7 3/8	3 3/4	1.97	3620
8	5/8	7 1/8	9 3/8	3 3/4	2.33	3620
10	3/4	8 3/8	11 5/8	4	4.91	5420
12	7/8	9 5/8	13 3/4	4 1/4	7.73	7540
14	7/8	10 1/4	15	4 1/4	8.28	7540
16	7/8	11 1/4	17	4 1/4	9.15	7540
18	1	12 5/8	19 1/8	4 3/4	13.48	9920
20	1	13 5/8	21 1/8	4 3/4	14.57	9920
24	1	15 5/8	25 1/8	4 3/4	16.87	9920
30	1	18 5/8	31 1/8	4 3/4	19.00	9920

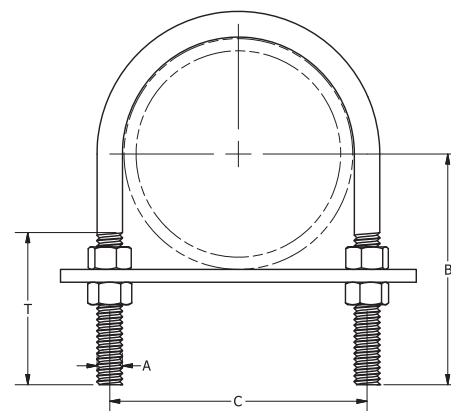

FIG. #166						
DI PIPE SIZE	A	B	C	T	WEIGHT EACH, LBS.	MAX. REC. LOAD, LBS.
3	1/2	4 1/4	4 5/8	3 1/4	0.84	2260
4	1/2	4 3/4	5 7/16	3 1/4	1.06	2260
6	5/8	6 1/4	7 3/4	4	2.23	3620
8	5/8	7 3/8	9 7/8	4	2.60	3620
10	3/4	8 5/8	12	4 1/4	4.49	5420
12	7/8	9 7/8	14 1/4	4 1/2	7.15	7540
14	7/8	11	16 3/8	5	8.10	7540
16	7/8	12	18 1/2	5	9.00	7540
18	1	13 3/8	20 5/8	5 1/2	13.20	9920
20	1	14 1/2	22 3/4	5 5/8	14.40	9920
24	1	16 5/8	27	5 3/4	16.80	9920
30	1	19 5/8	33 1/4	6	22.00	9920